

Spyglass Visual Inspection

Improve quality inspection with AI-driven real-time insights

Be the Change Agent



MARINER

Problem with Industrial Vision Inspection Systems

Manufacturers have made significant investments in machine vision systems for quality

The impact of poor quality is substantial - the high cost of reprocessing products, reduced time for production, wasted raw materials, and worst of all, dissatisfied customers that demand returns.

The cameras and lighting are of high quality with rapid image capture rates

Existing industrial vision systems employ high quality cameras, quality lighting and image capture technology.

Software, however, hasn't kept pace with current available technology

However, defect detection software has not kept pace – existing industrial vision systems are often unable to consistently and accurately identify small flaws that may have a large impact on customer satisfaction. False positives can bog down production schedules. Some manufacturers turn off their vision systems or ignore their results.

Spyglass Visual Inspection

Deep Learning. Delivered.



Real-time Defect Detection

100% product inspection
reduces false rejects by as
much as 30x



Alerting/Monitoring

When defect frequency
exceeds control limits, alert
personnel to investigate
/eliminate in real-time



Quality Analytics

Informs root cause analysis
efforts to more effectively
eliminate quality problems
before they occur

IMAGENET IMAGE CLASSIFICATION TOP-5 ERROR RATE

(ILSVRC, lower is better)

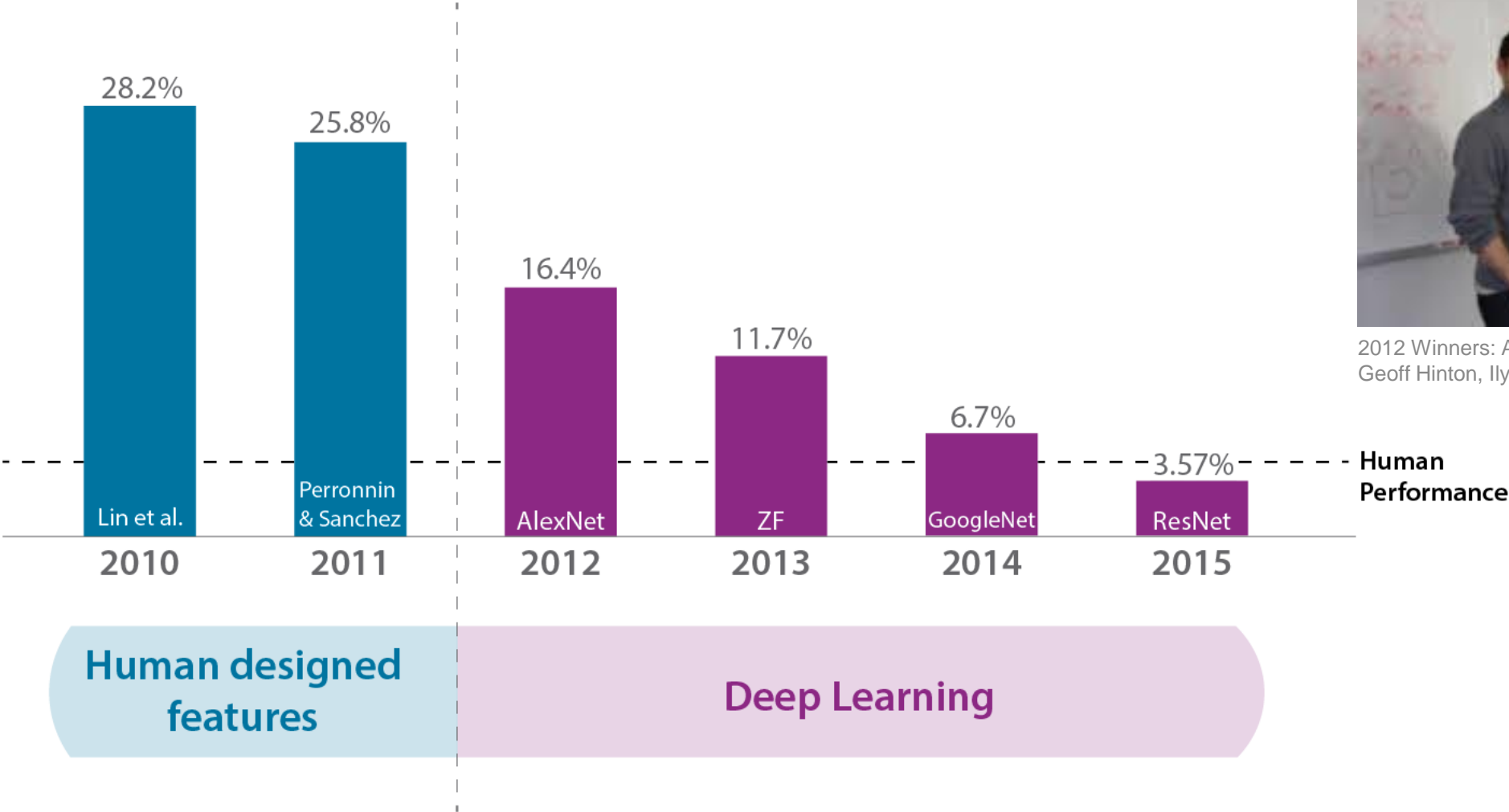

2012 Winners: Alex Krizhevsky, Geoff Hinton, Ilya Sutskever

TRADITIONAL MACHINE VISION

IMAGE CAPTURE

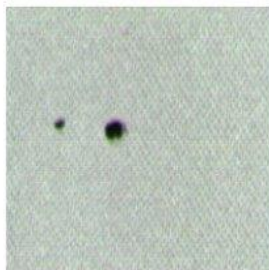

FEATURE EXTRACTION

These algorithms are typically designed once by vision system manufacturer, and "baked in" to production software.

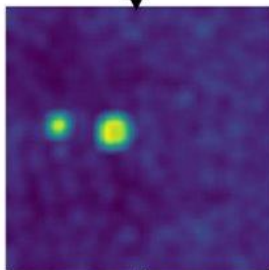

DECISIONING

May consist of many tunable parameters, often difficult to find optimal configuration, even for experts.



PREDICTIONS/RESULTS



DEEP LEARNING

IMAGE CAPTURE

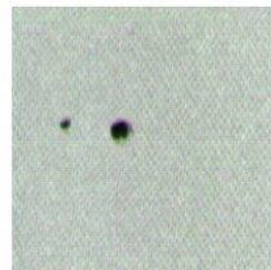

MODEL TRAINED ON YOUR DATA

Deep learning model trained using labeled examples from your experts, and updated as conditions change.

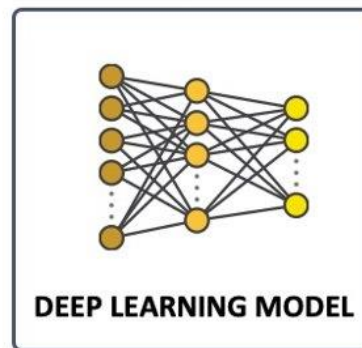

PREDICTIONS/RESULTS



Robust Scaling with Microsoft's & Intel's Partnership

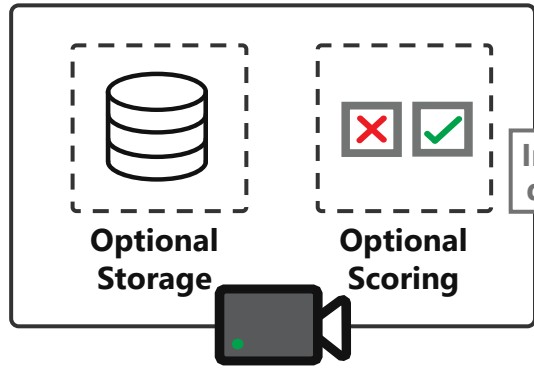

INDUSTRIAL VISION SYSTEM

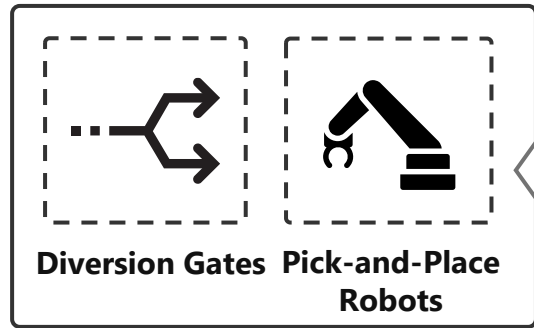

FACTORY EQUIPMENT

Images + meta data (LAN)

Control Signals
Modbus/
Profibus/
Devicenet/
Ethernet/IP

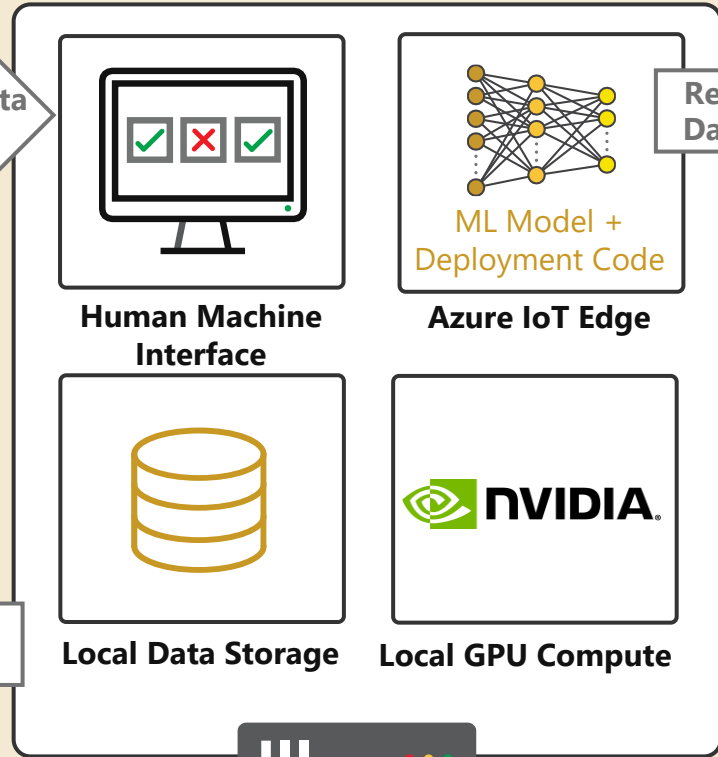

Edge Intelligence Server

Reporting + Data (MQTT)

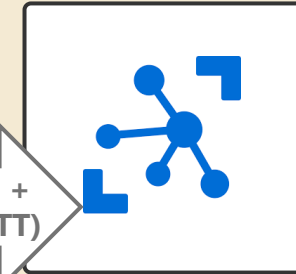

Azure IoT Hub



Monitoring + Alerting

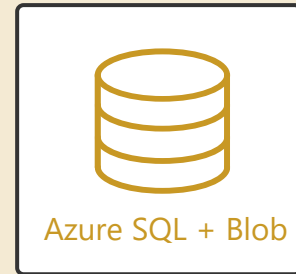

Azure SQL + Blob

Cloud Storage

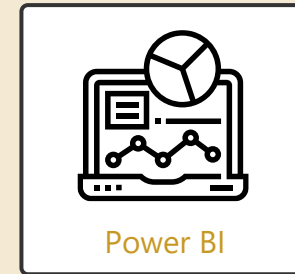

Power BI

Dashboards

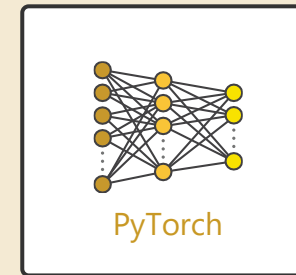

PyTorch

Model Training



Data Labeling

ON PREMISE CLOUD



Spyglass Visual Inspection

Case Study – Automotive Glass Manufacturer
From Proof of Value to Operationalized Solution

Business Challenges



- Current vision system struggles to differentiate water, dust, and dirt from true defects
- High false positive rate
- Unable to use pick & place robots

Business Impact



- Reduced false positives from $>23\%$ to 0.2%
- Model generalizes to broader datasets
- Model scales to production volumes efficiently
- Production lines running $10\% - 20\%$ faster
- Savings of $> \$4m / \text{year}$ at one facility alone



Spyglass Visual Inspection

Case Study –Automotive Interiors Manufacturer
From Proof of Value to Operationalized Solution



MARINER

Business Challenges



- Current vision system struggles to accurately identify & classify defects
- High false positive rate
- Excessive labor required to compensate for inaccuracies
- No alerting/monitoring or analytics

Existing vision system delivers high quality data, but limited analysis capabilities.

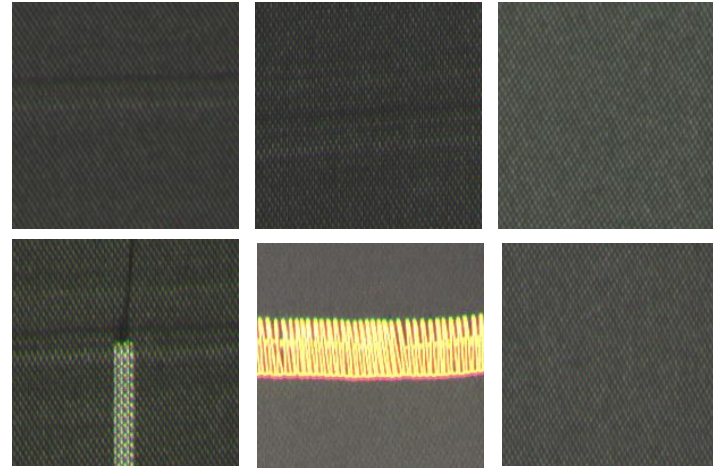

```
<defects>  
  <defect>  
    <dfct_type>spots</dfct_type>  
    <dfct_point>0</dfct_point>  
    <dfct_y_loc>21.20</dfct_y_loc>  
    <dfct_x_loc>44.92</dfct_x_loc>  
    <dfct_length>2.24409</dfct_length>  
    <dfct_width>2.40</dfct_width>  
    <dfct_code></dfct_code>  
    <dfct_delete>0</dfct_delete>  
    <roll_id>2236398</roll_id>  
    <dfct_cam>2</dfct_cam>  
    <speed>27.9</speed>  
    <dfct_area>0.02</dfct_area>  
    <dfct_index>1</dfct_index>  
    <dfct_slit>2</dfct_slit>  
    <dfct_img></dfct_img>  
  </defect>  
</defects>
```

0291MKAX.xml

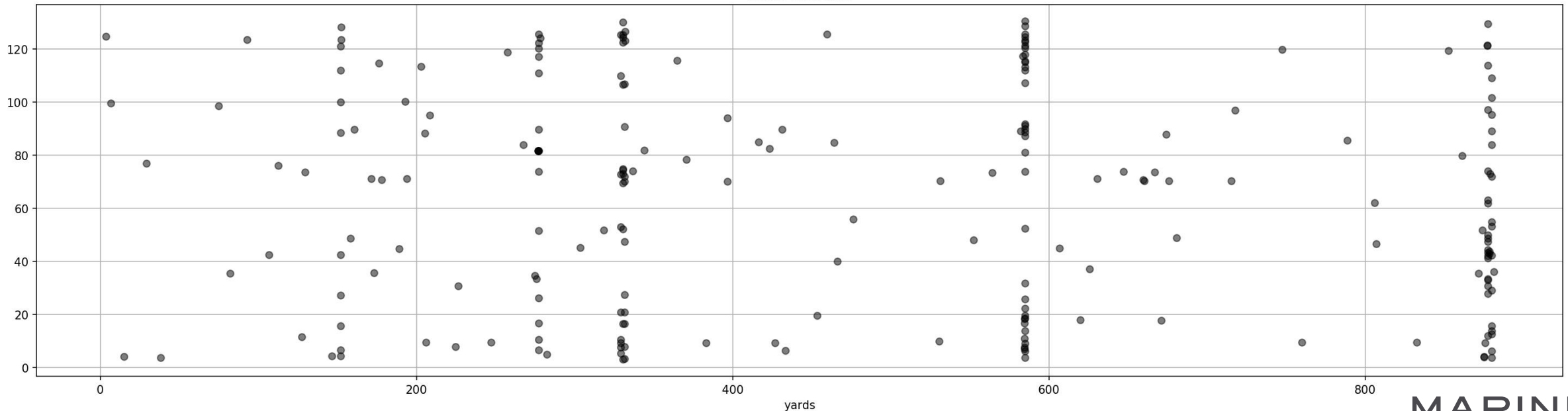

Using a Deep Learning-based approach, Mariner outperformed human inspection performance by 2-5x.

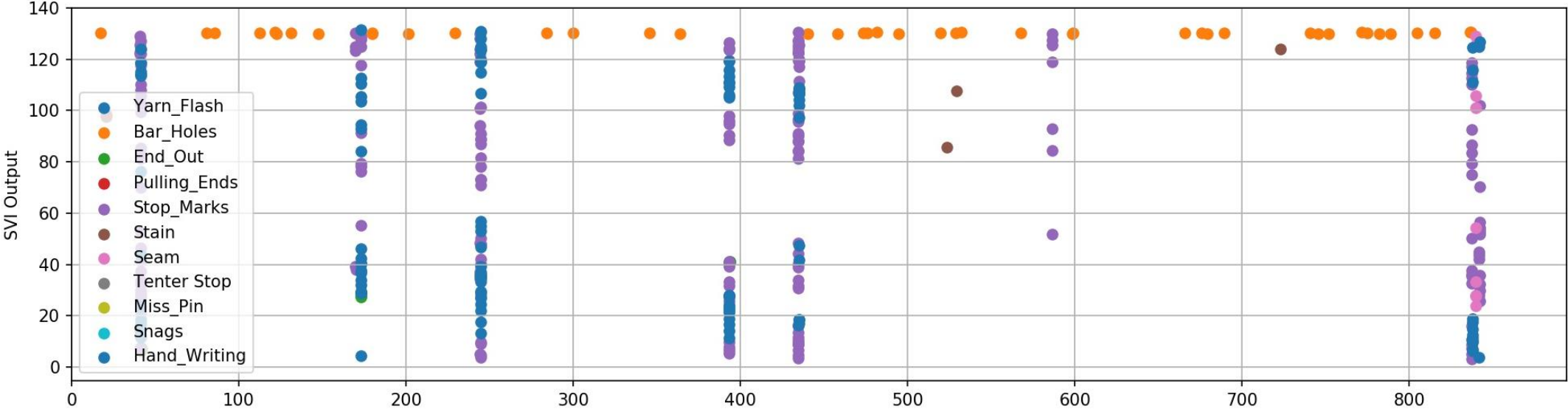
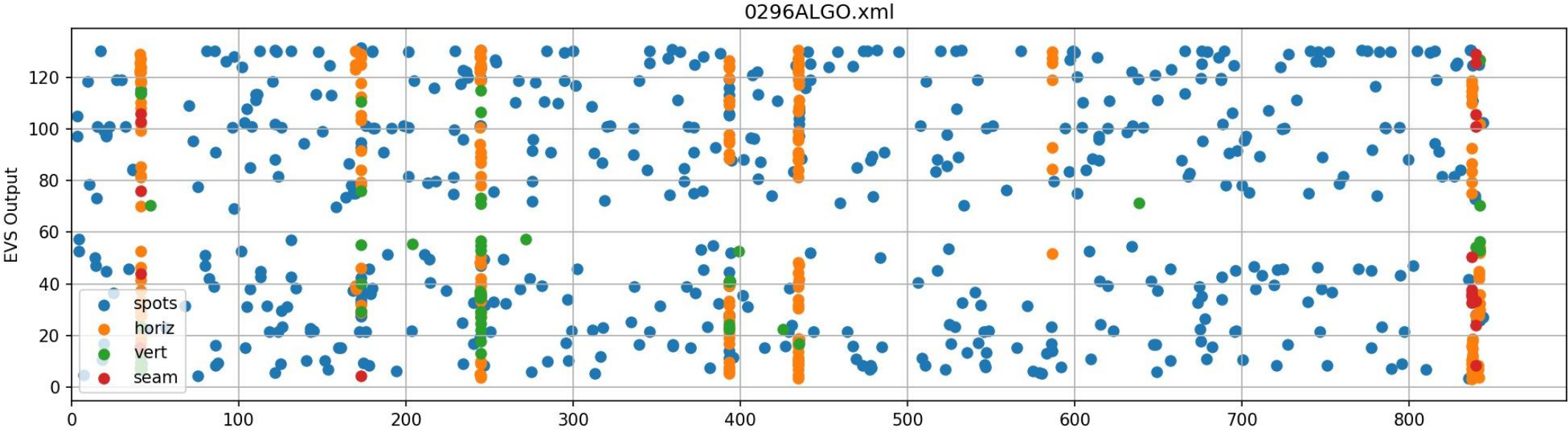

Business Impact



- Reduced false positives from 64% to 2.3%
- Model generalizes across colors and patterns
- Model scales to production volumes efficiently
- Significantly reduced manual effort required to compensate for high false positive rate
- Savings of \$2m/year

Spyglass Visual Inspection

Getting Started



MARINER

Jumpstart Your Digital Transformation

Be the Change Agent

Manufacturers are racing to adopt technology to gain Industry 4.0 traction. Spyglass Visual Inspection gives you a fast, low risk path to jumpstart your efforts.

Improve Operational Excellence

If you're like many of our customers, you're expending enormous labor expense compensating for the inaccuracy of your existing vision systems. This inefficiency prevents you from further automating your production lines reducing profits and increases false negatives – defective products you ship to your customers.

Gain First Mover Advantage

Many manufacturers are in commoditized markets. The only way to increase profits or strategic advantage is by reducing operational expenses. Deep learning can provide revolutionary improvements providing the competitive advantage you're looking for.

The Path to Better Quality

Our Guaranteed Approach to Visual Inspection



1

Define Success

The Spyglass team works with you to define your unique vision accuracy requirements.

2

Supply Images

Provide sets of images of your products that represent acceptable quality as well as images of each class of defect.

3

Prove it Works

Using supplied images, the Spyglass team builds an AI model demonstrating the success criteria



Thank You



MARINER

Leveraging Deep Learning for Quality Inspection

Spyglass Visual Inspection Reference Architecture

Existing Systems

Our solution adds AI + Vision defect detection to your existing systems increasing output and quality and reducing costs.

Edge Intelligence

Our gateway picks up images from your systems, scores them with local AI models and uploads the telemetry and images to the cloud.

Cloud Services

Spyglass Visual Inspection leverages Azure to store images, provide alerting services, and generate quality analytics..

Cloud Intelligence

Image scores are analyzed to detect alert conditions and turned into insights that optimize your operations and production.

Mgmt Experience

Your team uses Power BI to make decisions about production and can also extend/integrate our solution using our native APIs.

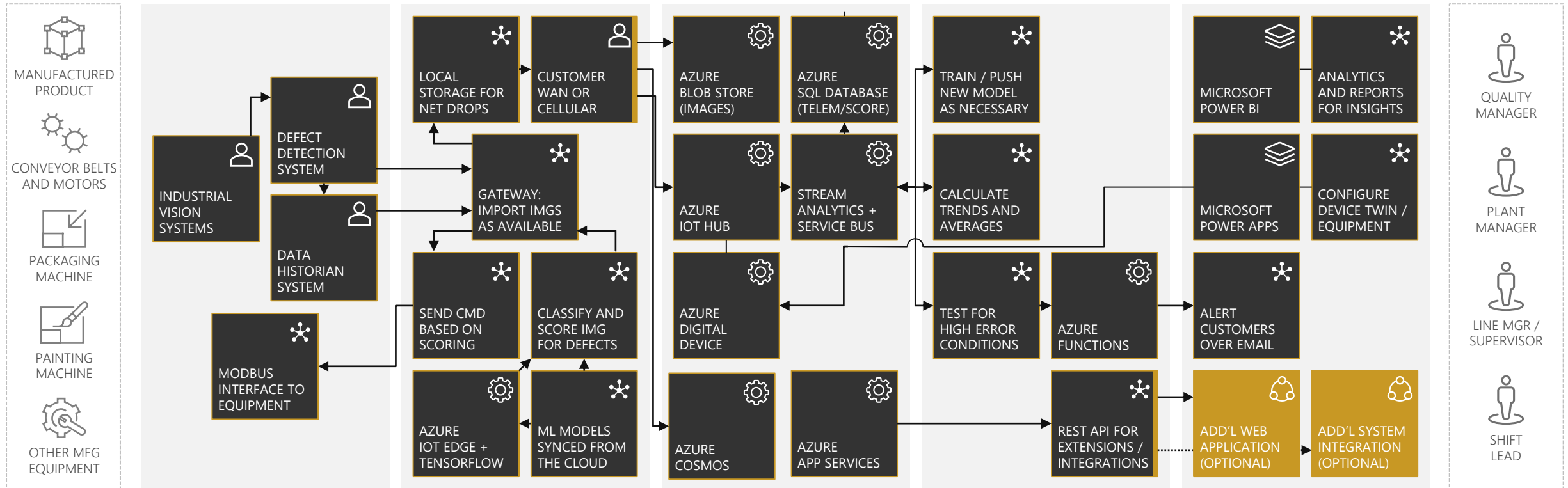

Partner component

Solution Builder component

Azure service

Microsoft product

Customer component